

Single Mode Single Window Wideband Tree Coupler Modules

Features:

- High Reliability
- Low WDL
- Ultra Low PDL
- High Directivity

Applications:

- Telecommunications
- LAN, WAN Systems
- Test Equipment & Fiber Sensors
- Network Monitoring
- RoHS Compliant Available



Specifications¹:

Parameter	Unit		Grade 2A ²			
Operating wavelength	nm		1310 or 1550+/-40			
Configuration			N ² 4 (N=1, 2)	N ² 8 (N=1, 2)	N ² 16 (N=1, 2)	N ² 32 (N=1, 2)
Insertion Loss	Typ.	dB	6.2	9.3	12.4	15.5
	Max.		6.8	10.2	13.6	17.0
Uniformity	Max.	dB	1.0	1.5	2.0	2.5
PDL	Max.	dB	0.2	0.3	0.4	0.5
Directivity	Min.	dB	55			
Thermal Stability	Max.	dB/°C	0.003	0.004	0.005	0.006
Fiber Length	m		1.0+/-0.1, or on request			
FiberType	Corning SMF-28e, 900mm loose tube, 2mm or 3mm cable					
Operating Temperature	°C		0~70			
Storage Temperature	°C		-40~85			
Package (L ² W ² H) ²	mm		1: 106 ² 79 ² 10 ²		2: 125 ² 96 ² 15 ²	
					3: 145 ² 116 ² 18 ²	

1. Above values referred without connectors.

2. Smaller package size, LGX box and rack mount package are available.

Dimension:

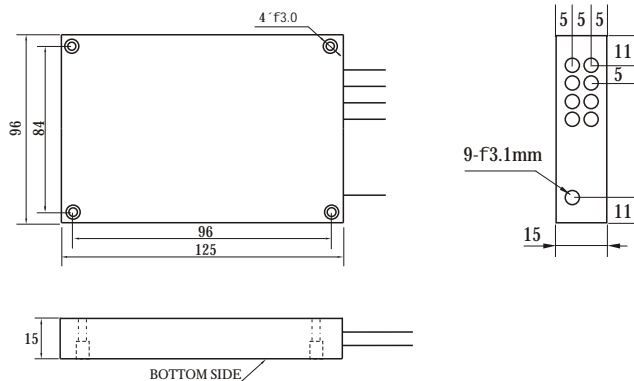

Figure 1. Package for 1x8 Splitter

Order Information:

SSWM - X - XXXX - XXXX - XXX - XX
 A B C D E

A	Grade	A=Grade ² A ²
B	Central Wavelength	1310=1310nm
		1550=1550nm
C	Fiber Type	900L=900mm loose tube
		2000=2mm cable
		3000=3mm cable
D	Type	1x4=1x4
		1x8=1x8
		1x16=1x16
		1x32=1x32
E	Connector	NN=W/O connector
		XY=With connector ¹

1. Please specify the type of connector when ordering if connector is required.

Mechanical Type	Other	SC	FC	ST	MU	LC
X	0	1	2	3	4	5
Physical Contact Type	Other	PC	UPC	APC		
Y	0	1	2	3		